

**ISTRUZIONI DI MONTAGGIO IMPUGNATURA (IN) FINITO SU PLACCA LUNGA - CIECA / PATENT / YALE - ( FISSAGGIO CON VITI LEGNO).  
ASSEMBLING INSTRUCTION SCHEME (IN)FINITO HANDLES ON LONG PLATE - BLIND/KEY HOLE / CYLINDER HOLE (WOOD SCREWS)**

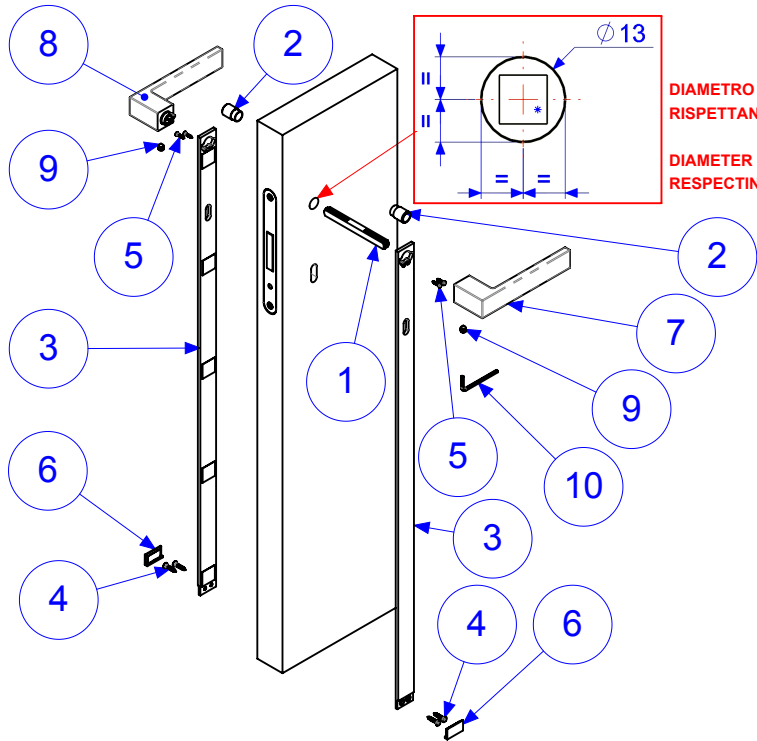

**DIAMETRO 13mm DIMENSIONE DEL FORO DA ESEGUIRE SULLA PORTA RISPETTANDO IL CENTRO DEL QUADRO SERRATURA.**

**DIAMETER 13mm: SIZE OF THE HOLE TO BE DRILLED ON THE DOOR, RESPECTING THE CENTERING WITH THE SQUARE SPINDLE HOLE.**

1	FERRO QUADRO	SQUARE SPINDLE
2	2 CENTRATORI PER FORO MANIGLIA D.12,5/14mm	2 ea. 12,5/14mm D. CENTERING GUIDE FOR LEVER HANDLE
3	PLACCA (N) FINITO LUNGA	(IN) FINITO LONG PLATE
4	KIT N.4 VITI TSP Tg.Croce 3,5x16	KIT of 4 mm3,5x16 SCREWS
5	KIT N.4 VITI TSP Tg.Croce 3x12	KIT of 4 mm3x12 SCREWS
6	PIASTRINA (IN)FINITO COPRIVITE	(IN)FINITO SCREWS CONCEALING PLATE
7	IMPUGNATURA (IN)FINITO DESTRA	(IN)FINITO RIGHT HAND LEVER
8	IMPUGNATURA (IN)FINITO SINISTRA	(IN)FINITO LEFT HAND LEVER
9	KIT N.2 VITI GRANO M6	KIT of 2 M6 GRUB SCREWS
10	CHIAVETTA ESAGONALE 3mm	3mm ALLEN KEY

INSERIRE NELLA SERRATURA IL FERRO QUADRO (1) MANTENENDO LA SCANALATURA VERSO IL BASSO.

PLACE THE SQUARE SPINDLE (1) THROUGH THE LOCK WITH THE GROOVE FACING DOWN.

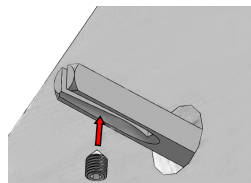

SU ENTRAMBE I LATI INSERIRE I CENTRATORI (2) SUL QUADRO (1).

PLACE THE 12,5/14mm D. CENTERING GUIDES (2) ON THE SQUARE SPINDLE (1) ON BOTH SIDES OF THE DOOR.

Fig.02

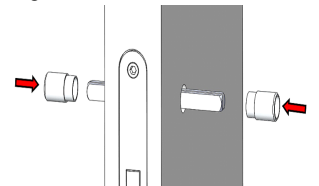

FARE ATTENZIONE A MANTENERE LA STESSA SPORGENZA DEL FERRO QUADRO (1) SU ENTRAMBI I LATI DEL BATTENTE COME INDICATO IN FIG.03, ED IL CORRETTO POSIZIONAMENTO COME INDICATO IN FIG.04

PAY ATTENTION TO KEEP THE SAME PROJECTION OF THE SQUARE SPINDLE (1) ON BOTH SIDES OF THE DOOR LEAF AS SHOWN IN Fig.03, AND THE CORRECT POSITION AS SHOWN IN Fig.04.

Fig.03

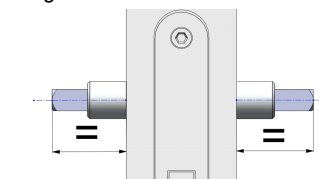
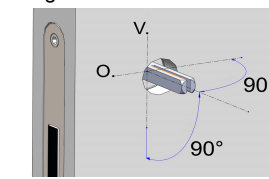

Fig.04



TOGLIERE LA PELLICOLA PROTETTIVA DELL'ADESIVO PRESENTE SULLA FACCIATA POSTERIORE DELLE PLACCHE (3).

REMOVE THE PROTECTIVE FILM FROM THE ADHESIVE ON THE BACK OF THE PLATE(3).

Fig.05

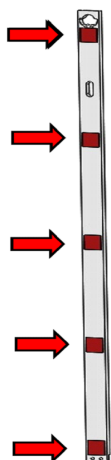

SU ENTRAMBE I LATI : INSERIRE LA PLACCA (3) SUL CENTRATORE (2) COME DA FIG.06, MANTENENDO IL CORRETTO ALLINEAMENTO CON IL PROFILO DELLA PORTA COME INDICATO IN FIG.07. POI COMPLETARE IL FISSAGGIO CON LE VITI (4) PER I FORI INFERIORI, E LE VITI (5) PER I FORI SUPERIORI. TOGLIERE I DUE CENTRATORI (2) FIG.08

ON BOTH SIDES: APPLY THE PLATE (3) ON THE 12,5/14mm D. CENTERING GUIDE (2) AS SHOWN IN Fig.06, KEEPING THE CORRECT ALIGNMENT WITH THE DOOR PROFILE AS INDICATED IN Fig.07, THEN COMPLETE THE FASTENING WITH THE PROVIDED SCREWS (4) FOR THE LOWER HOLES, AND WITH THE SCREWS (5) FOR THE UPPER HOLES. REMOVE THE TWO CENTERING GUIDES (2) AS PER Fig.08.

Fig.06

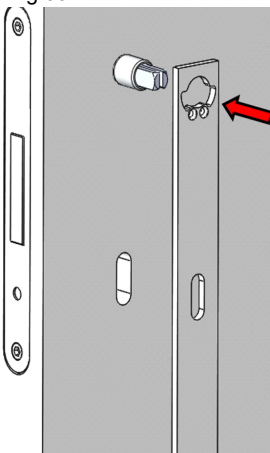

Fig.07

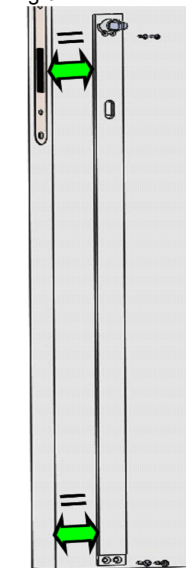
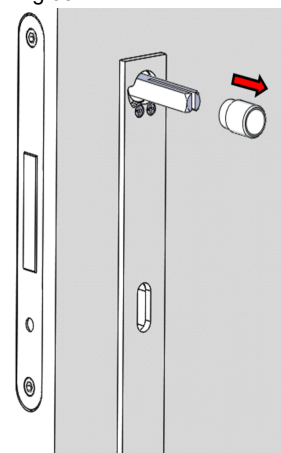

Fig.08



TOGLIERE LA PELLICOLA PROTETTIVA DELL'ADESIVO PRESENTE SULLA FACCIATA POSTERIORE DELLE PIASTRINE COPRI VITE (6).

REMOVE THE PROTECTIVE FILM FROM THE ADHESIVE ON THE BACK OF THE SCREWS CONCEALING PLATE (6)

Fig.09

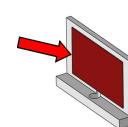

SU ENTRAMBE I LATI : APPLICARE LA PIASTRINA COPRI VITE(6) FIG.10, RISPETTANDO IL CORRETTO ALLINEAMENTO CON IL PROFILO DELLA PLACCA (3) FIG.11.

ON BOTH SIDES: APPLY THE SCREW CONCEALING PLATE (6) AS PER Fig.10, RESPECTING THE CORRECT ALIGNMENT WITH THE PROFILE OF THE PLATE (3) AS SHOWN IN Fig.11.

Fig.10

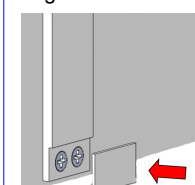

Fig.11



APPLICARE LE IMPUGNATURE (7 & 8) SUL FERRO QUADRO (1), FISSARE LA PRIMA IMPUGNATURA CON LA VITE GRANO (9) UTILIZZANDO LA CHIAVETTA ESAGONALE (10), FISSARE ANCHE LA SECONDA IMPUGNATURA TENENDO ENTRAMBE LE IMPUGNATURE BENE IN APPOGGIO SULLE PLACCHE.

SLIDE BOTH LEVER HANDLES (7 & 8) ON THE SQUARE SPINDLE (1). FIX THE FIRST LEVER HANDLE WITH THE M6 GRUB SCREW (9) BY USING THE ALLEN KEY (10), FIX THE SECOND LEVER HANDLE BY KEEPING BOTH OF THEM FIRMLY AGAINST THE PLATES AS PER Fig.13.

Fig.12

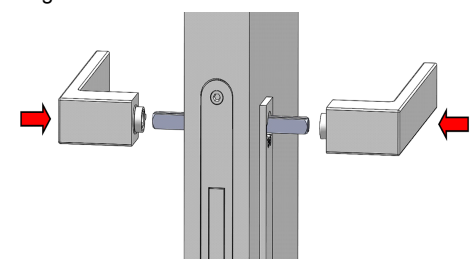

Fig.13

