

ISTRUZIONI DI MONTAGGIO IMPUGNATURA (IN) FINITO SU PLACCA LUNGA CON NOTTOLINO WC - (fissaggio con viti legno). ASSEMBLING INSTRUCTION SCHEME (IN)FINITO HANDLES ON LONG PLATE WITH TURN&RELEASE (WOOD SCREWS)

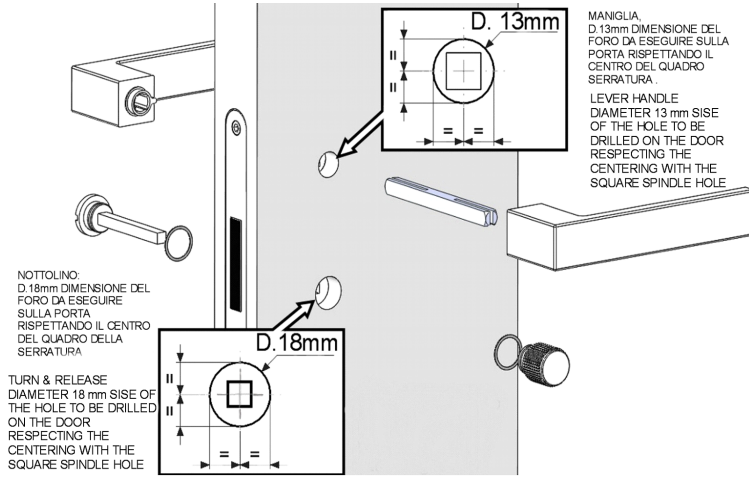
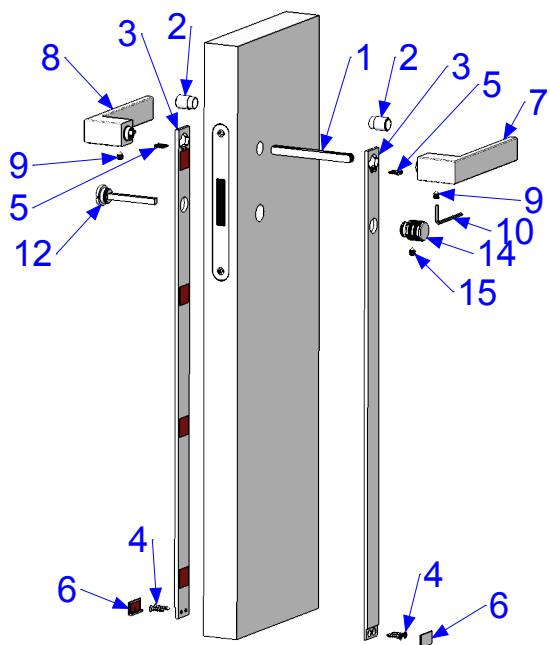

1	FERRO QUADRO	SQUARE SPINDLE
2	2 CENTRATORI D.12,5/14 FORO MANIGLIA	2 ea.12.5/14mm D. CENTERING GUIDE FOR LEVER HOLE
3	PLACCA (IN) FINITO	(IN)FINITO PLATE
4	KIT N.4 VITI TSP Tg.Croce 3,5x16	KIT of 4 mm3,5 x16 SCREWS
5	KIT N.4 VITI TSP Tg.Croce 3x12	KIT of 4 mm3x12 SCREWS
6	PIASTRINA (IN)FINITO COPRIVITE	(IN)FINITO SCREWS CONCEALING PLATE
7	IMPUGNATURA DESTRA (IN)FINITO	(IN)FINITO RIGHT HAND LEVER
8	IMPUGNATURA SINISTRA (IN)FINITO	(IN)FINITO LEFT HAND LEVER
9	KIT N.2 VITI GRANO M6	KIT of 2 M6 GRUB SCREWS
10	CHIAVETTA ESAGONALE 3mm	mm3 ALLEN KEY
11	RONDELLA NYLON D.16x19mm	mm16x19 D. NYLON WASHER
12	NOTTOLINO EMERGENZA ESTERNO	EMERGENCY RELEASE
13	1 CENTRATORE D.16 PER FORO NOTTOLINO	1 ea. 16mm D. CENTERING GUIDE FOR TURN&RELEASE HOLE
14	NOTTOLINO GIREVOLE INTERNO	PRIVACY SNIB TURN
15	N.1 VITE GRANO M6	1 ea. M6 GRUB SCREW

INSERIRE NELLA SERRATURA IL FERRO QUADRO (1) MANTENENDO LA SCANALATURA VERSO IL BASSO.

PLACE THE SQUARE SPINDLE (1) THROUGH THE LOCK WITH THE GROOVE FACING DOWN.
Fig.01

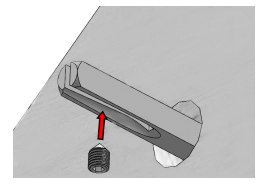

SU ENTRAMBE I LATI INSERIRE I CENTRATORI (2) 12,5/14mm SUL QUADRO (1)

PLACE THE 12,5/14mm D. CENTERING GUIDE (2) ON THE SQUARE SPINDLE (1) ON BOTH SIDES.
Fig.02

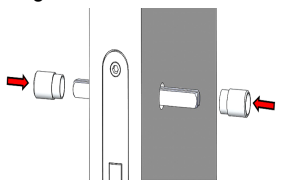

FARE ATTENZIONE A MANTENERE LA STESSA SPORGENZA DEL FERRO QUADRO (1) SU ENTRAMBE I LATI DEL BATTENTE COME INDICATO IN FIG.03, ED IL CORRETTO POSIZIONAMENTO COME INDICATO IN FIG.04.

PAY ATTENTION TO KEEP THE SAME PROJECTION OF THE SQUARE SPINDLE (1) ON BOTH SIDES OF THE DOOR LEAF AS SHOWN IN Fig.03, AND THE CORRECT POSITION AS SHOWN IN Fig.04.
Fig.03

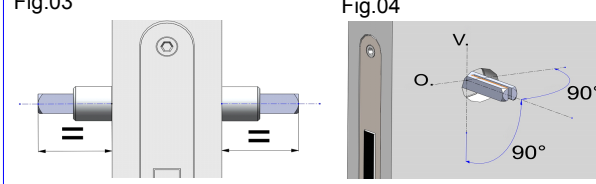

TOGLIERE LA PELLICOLA PROTETTIVA DELL'ADESIVO PRESENTE SULLA FACCIA POSTERIORE DELLE PLACCHE (3).

REMOVE THE PROTECTIVE FILM FROM THE ADHESIVE ON THE BACK OF THE PLATE (3).
Fig.05

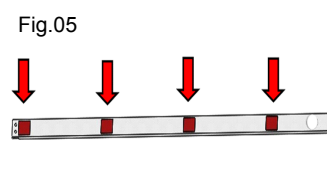

INSERIRE IL NOTTOLINO (12) NEL QUADRO DELLA SERRATURA FINO ALLA BATTUTA SULLA PORTA, POI DALL'ALTRO LATO DELLA PORTA INSERIRE SUL QUADRO DEL NOTTOLINO (12) IL CENTRATORE D.16 (13).

PLACE THE EMERGENCY RELEASE (12) THROUGH THE LOCK SQUARE UNTIL IT IS FLUSH AGAINST THE DOOR. THEN, ON THE OTHER SIDE OF THE DOOR PLACE THE 16mm D. CENTERING GUIDE FOR TURN&RELEASE (13) ON THE EMERGENCY RELEASE SQUARE SPINDLE (12).
Fig.06



DAL LATO DEI 2 CENTRATORI (2&13) APPLICARE LA PLACCA (3) FIG.08, FACENDO ATTENZIONE AL CORRETTO ALLINEAMENTO CON IL PROFILO DELLA PORTA FIG.09. RIMUOVERE IL CENTRATORE D.16 IN BASSO (13) E IL NOTTOLINO EMERGENZA (12)

ON THE DOOR SIDE WHERE BOTH CENTERING GUIDES (2 & 13) ARE SET, APPLY THE PLATE (3) AS SHOWN IN Fig.08, PAYING ATTENTION TO THE CORRECT ALIGNMENT WITH THE DOOR PROFILE AS SHOWN IN Fig.09. REMOVE THE 16mm D. CENTERING GUIDE FOR TURN&RELEASE (13) AND THE EMERGENCY RELEASE (12)
Fig.08

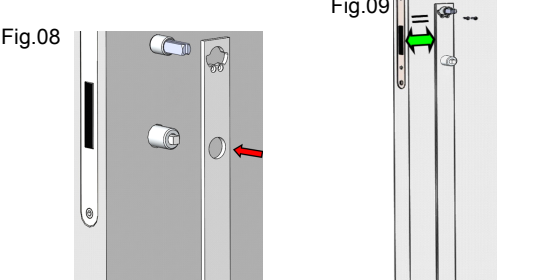

DAL LATO PLACCA INSERIRE IL NOTTOLINO (12) FINO ALLA BATTUTA SULLA PLACCA FIG.10, DALL'ALTRO LATO INSERIRE SUL QUADRO DEL NOTTOLINO (12) IL CENTRATORE D.16 (13).

ON THE DOOR SIDE OF THE PLATE, PLACE THE EMERGENCY RELEASE (12) THROUGH THE LOCK SQUARE UNTIL IT IS FLUSH AGAINST THE PLATE AS PER Fig.10, ON THE OTHER SIDE OF THE DOOR PLACE THE 16mm D. CENTERING GUIDE FOR TURN&RELEASE (13) ON THE EMERGENCY RELEASE SQUARE SPINDLE (12)
Fig.10

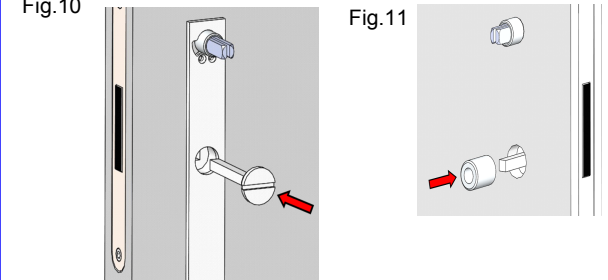

DAL LATO DEI 2 CENTRATORI (2&13) APPLICARE LA PLACCA (3) FIG.12, FACENDO ATTENZIONE AL CORRETTO ALLINEAMENTO CON IL PROFILO DELLA PORTA FIG.13.

THEN AGAIN, ON THE DOOR SIDE WHERE BOTH CENTERING GUIDES (2 & 13) ARE SET APPLY THE OTHER PLATE (3) AS SHOWN IN Fig.12, PAYING ATTENTION TO THE CORRECT ALIGNMENT WITH THE DOOR PROFILE AS SHOWN IN Fig.13.
Fig.12

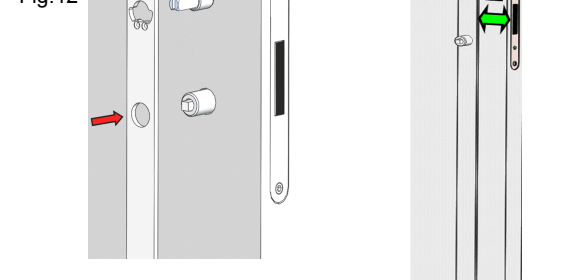

ESTRARRE I DUE CENTRATORI D.12,5/14 (2), IL CENTRATORE D.16 (13) ED IL NOTTOLINO (12).

REMOVE ALL CENTERING GUIDES (2 & 13), AND THE EMERGENCY RELEASE (12)
Fig.14

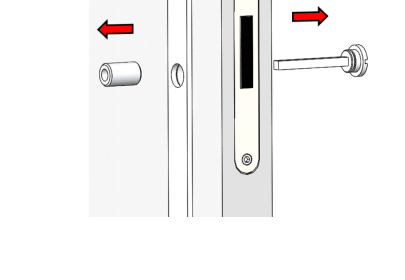

**ISTRUZIONI DI MONTAGGIO IMPUGNATURA (IN) FINITO SU PLACCA LUNGA CON NOTTOLINO WC - (fissaggio con viti legno).
ASSEMBLING INSTRUCTION SCHEME (IN)FINITO HANDLES ON LONG PLATE WITH TURN&RELEASE (WOOD SCREWS)**

SUI NOTTOLINI APPLICARE LE RONDELLE IN NYLON (11) INSERIRE IL NOTTOLINO (12) FINO ALLA BATTUTA SULLA PLACCA, POI INSERIRE IL NOTTOLINO (14) SUL QUADRO DEL NOTTOLINO EMERGENZA (13) FINO ALLA BATTUTA SULLA PLACCA , FISSARE IL NOTTOLINO CON LA VITE GRANO (15) UTILIZZANDO LA CHIAVETTA (10) FIG.16.
ADESSO VERIFICARE IL CORRETTO FUNZIONAMENTO DEL NOTTOLINO CON LA MANDATA DELLA SERRATURA.

SLIDE THE NYLON WASHER (11) ON THE EMERGENCY RELEASE AND ON THE PRIVACY SNIB TURN. INSERT THE EMERGENCY RELEASE (12) UNTIL IT IS FLUSH AGAINST THE PLATE, THEN MOUNT THE PRIVACY SNIB TURN (14) ON THE SQUARE SPINDLE ON THE OTHER SIDE OF THE DOOR UNTIL IT IS FLUSH AGAINST THE PLATE AND FIX IT WITH THE M6 GRUB SCREW (15) BY USING THE ALLEN KEY (10) AS PER Fig.16.
CHECK THE CORRECT FUNCTIONING OF THE TURN&RELEASE BY OPERATING THE LATCH.

Fig.15

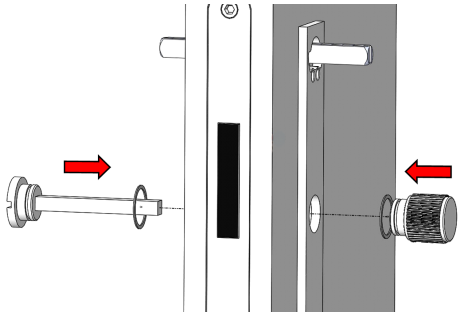
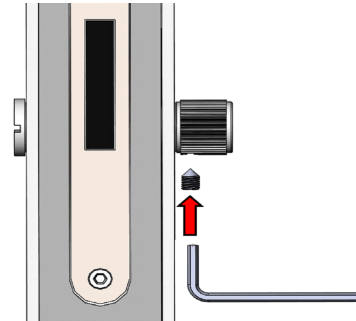

Fig.16



FISSARE ENTRAMBE LE PLACCHE (3) CON LE VITI (4) PER I FORI INFERIORI , E LE VITI (5) PER I FORI SUPERIORI.

COMPLETE THE FASTENING OF THE PLATES (3) WITH THE PROVIDED SCREWS (4) FOR THE LOWER HOLES, AND WITH THE SCREWS (5) FOR THE UPPER HOLES.

Fig.17

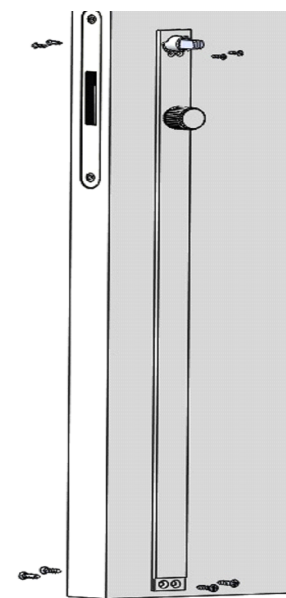

TOGLIERE LA PELLICOLA PROTETTIVA DELL'ADESIVO PRESENTE SULLA FACCIATA POSTERIORE PIASTRINE COPRI VITE (6).

REMOVE THE PROTECTIVE FILM FROM THE ADHESIVE ON THE BACK OF THE SCREWS CONCEALING PLATE (6).

Fig.18

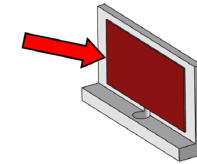

SU ENTRAMBE I LATI : APPLICARE LA PIASTRINA COPRI VITE(6) FIG.19, RISPETTANDO IL CORRETTO ALLINEAMENTO CON IL PROFILO DELLA PLACCA (3) FIG.20.

ON BOTH SIDES: APPLY THE SCREW CONCEALING PLATE (6) AS PER Fig.19, RESPECTING THE CORRECT ALIGNMENT WITH THE PROFILE OF THE PLATE (3) AS SHOWN IN Fig.20.

Fig.19

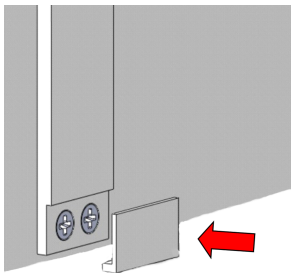
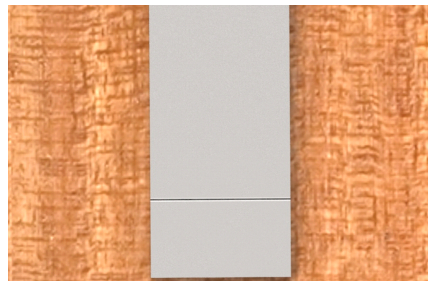

Fig.20



APPLICARE LE IMPUGNATURE (7 & 8) SUL FERRO QUADRO (1) , FISSARE LA PRIMA IMPUGNATURA CON LA VITE GRANO (9) UTILIZZANDO LA CHIAVETTA ESAGONALE (10) , FISSARE ANCHE LA SECONDA IMPUGNATURA TENENDO ENTRAMBE LE IMPUGNATURE BENE IN APPOGGIO SULLE PLACCHE.

SLIDE BOTH LEVER HANDLES (7 & 8) ON THE SQUARE SPINDLE (1). FIX THE FIRST LEVER HANDLE WITH THE M6 GRUB SCREW (9) BY USING THE ALLEN KEY (10), THEN FIX THE SECOND LEVER HANDLE BY KEEPING BOTH OF THEM FIRMLY AGAINST THE PLATES AS PER Fig.22.

Fig.21

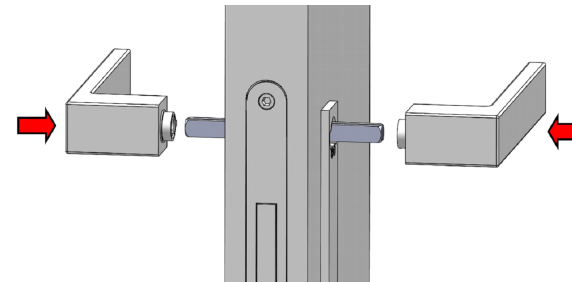

Fig.22

